

## Wafer check valve, Article CSD-6464

### Diameter DN 15 (1/2") up to DN 350 (14")

Wafer check valves to prevent media backflow in all fluid processes, whether in liquid, gaseous or vaporous forms. The return spring ensures that the valve disk closes securely. The exact valve disc guidance through the body ribs and a safety spring cap guarantee a high level of tightness. Optionally, metallic or soft sealing with O-ring in the valve disc (EPDM / NBR / FPM / PTFE).

A special body contour with an integrated centering collar enables installation between flanges of different pressure classes. The direction arrow embossed on the body indicates the direction of flow.

- Installation between flanges according to DIN EN 1092-1 Form B1, PN 6 - 40 from DN 125 (5") PN 10 / PN 16 and ASME B 16.5, class 150/300** (use suitable flange seals for this!)
- Overall length according to DIN EN 558-1, series 49 (DIN 3202-K4), from DN 250 DIN EN 558-2, series 52 (DIN 3202-K5)**
- Installation in any pipe position** (vertical/horizontal) **possible**
- Standard spring (stainless steel F316) temperature limit +300° C**

**Optional:** Oil and grease-free cleaned for use with oxygen, special springs up to max. 1000 mbar, springs made of Hastelloy C4 (up to +400° C) or Nimonic (up to +500° C), execution without spring (vertical installation; flow from bottom to top)

**ATTENTION:** Do not use it as a safety or vacuum valve !



CSD DN 15 - DN 100

	0036 Diameter DN 32 - DN 350
	Ambient -50° C ... +80° C
	Medium (depends from pressure) metall seated -200° C ... +500° C NBR -30° C ... +120° C EPDM -50° C ... +130° C FPM (Viton) -20° C ... +200° C PTFE -200° C ... +200° C

Pos.	Description	Material
1	body	stainless steel A351 CF8M
2	valve disc	stainless steel A182 F316/A351 CF8M
3	spring	stainless steel A182 F316
4	spring cap	stainless steel A182 F316

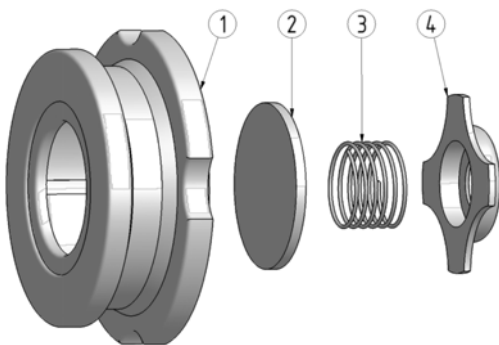

- Product classification DGRL 2014/68/EU, Fluidgroup I
- Body strenght DIN EN 12516-2
- Design pressure PN 40
- Marking EN 19, MSS SP-25
- Testing DIN EN 12266 P10 / P11 / P12
- Application limits DIN EN 1092-1 and AD-leaflets W 10
- Tightness DIN 12266-1,  
 Leakage rate D (metal seated / PTFE)  
 Leakage rate A, soft seated  
 (NBR / EPDM / FPM)

Diameter	Pressure / temperature limits metal sealing (max.)						
	-200	RT	100	200	300	400	500
DN 15 - DN 100							
t (°C)	-200	RT	100	200	300	400	500
PS (bar)	40	40	37,5	31,6	27,6	25,7	24,3

CSD-6464\_2021\_ENG\_Rev. 0

## Wafer check valve, Article CSD-6464

### Diameter DN 15 (1/2“) up to DN 100 (4“)

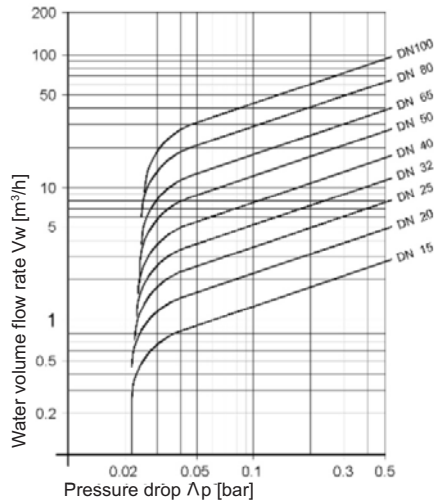

#### Pressure drop diagram

Pressure drop diagram for water at 20° C with an open valve and horizontal flow. To determine the pressure loss for other media is the equivalent water volume flow to calculate.

$$\dot{V}_w = \dot{V} \sqrt{\frac{\rho}{1000}}$$

$\dot{V}_w$  = equivalent water volume flow in m<sup>3</sup>/h

$\rho$  = density of the medium in kg/m<sup>3</sup> (operating condition)

$\dot{V}$  = Volume flow of the medium in m<sup>3</sup>/h (operating condition)

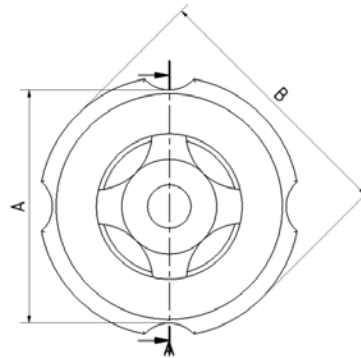
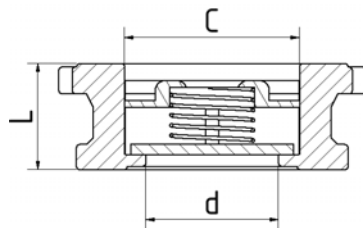

Diameter	article-no.	L (mm)	d (mm)	C (mm)	A (mm)	B (mm)	opening pressure (mbar)				KV-value (m <sup>3</sup> /h)	weight (kg)
							direction of flow with spring			without spring		
							→	↑	↓			
DN 15	286.1462.6.11	16,0	15,0	26,0	44,0	51,0	20	25	15	5	3,8	0,1
DN 20	286.1462.6.13	19,0	20,0	31,0	54,0	61,0	20	25	15	5	6,8	0,2
DN 25	286.1462.6.15	22,0	25,0	36,0	63,5	71,0	20	25	15	5	11,0	0,3
DN 32	286.1462.6.18	28,0	32,0	44,0	73,0	79,5	20	27	13	7	15,0	0,5
DN 40	286.1462.6.19	31,5	39,0	51,5	82,5	92,0	20	28	12	8	22,0	0,7
DN 50	286.1462.6.21	40,0	48,0	62,0	96,0	107,0	20	29	11	9	35,0	1,1
DN 65	286.1462.6.24	46,0	62,0	77,5	116,0	127,0	20	30	10	10	52,0	1,6
DN 80	286.1462.6.25	50,0	72,5	92,0	132,0	142,0	20	31	9	11	84,0	3,0
DN 100	286.1462.6.27	60,0	89,0	107,0	152,0	162,0 / 168,0	20	33	7	13	120,0	3,5

#### Additional letter after article no. for soft seated and special designs

	O-Ring <b>EPDM</b> -50°C up to +130°C	O-Ring <b>NBR</b> -30°C up to +120°C	O-Ring <b>FKM</b> -20°C up to +200°C	O-Ring <b>PTFE</b> -200°C up to +200°C	special spring up to 1000 mbar	Centering ring from DN 200 for Installation between flanges PN25 / PN40 ANSI	Execution <b>oil and grease free</b> (use of oxygen)
Add. for article no.:	<b>-E</b>	<b>-N</b>	<b>-V</b>	<b>-P</b>	<b>-SF</b> _____	<b>-FL</b>	<b>-O2</b>

CSD-6464\_2021\_ENG Rev. 0

## Wafer check valve, Article CSD-6464

Diameter DN 125 (5") up to DN 350 (14")

From nominal size DN 125, one-piece design of valve disc / spindle, guided and mounted in a spring cross. This guarantees a safe and exact closing on the machined sealing surface in the body, a high level of tightness can be guaranteed. The direction arrow embossed on the housing indicates the direction of flow.

Optionally, metallic or soft sealing with O-ring in the valve plate (EPDM / NBR / FPM / PTFE).

**Other design features and limits of use as before circumscribed.**

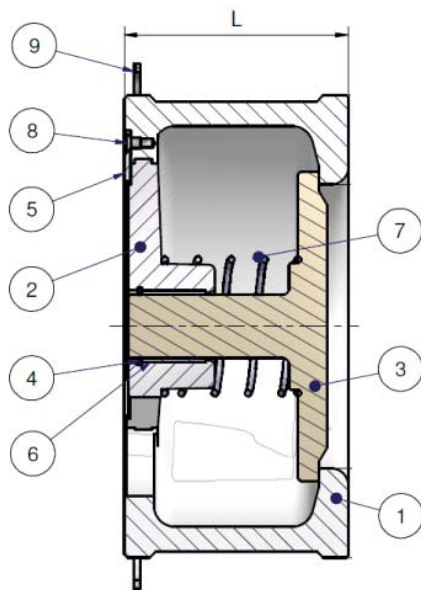
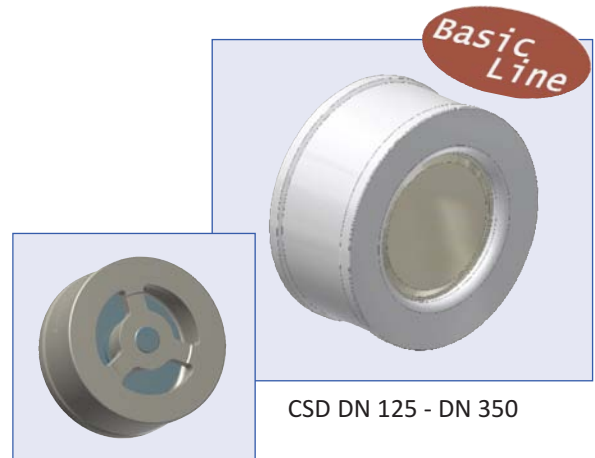

Pos.	Description	Material
1	body	stainless steel A351 CF8-M
2	spring cross	stainless steel A351 CF8-M
3	valve plate	stainless steel A351 CF8-M
4	safety ring (DN 125 - DN 150)	stainless steel
5	anti twist holder (DN 125 - DN 150)	stainless steel A351 CF8-M
6	bearing	PTFE MoS2/Stainless steel
7	spring	stainless steel A316L
8	allen screw	stainless steel A4
9	centre ring	stainless steel A182 F304

Diameter	Pressure / temperature limits metal sealing (max.)					
DN 125 - DN 350						
t (°C)	-200	RT	150	300	400	500
PS (bar)	40	40	36,3	29,7	27,4	26,4

### Additional letter after article no. for soft seated and special designs

Add. for article no.:	O-Ring <b>EPDM</b> -50°C up to +130°C	O-Ring <b>NBR</b> -30°C up to +120°C	O-Ring <b>FKM</b> -20°C up to +200°C	O-Ring <b>PTFE</b> -200°C up to +200°C	<b>special spring up to 400 mbar</b>	Centering ring from DN 200 for Installation between flanges PN 25 / PN 40 ANSI 150/300	Execution <b>oil and grease free</b> (use of oxygen)
	<b>-E</b>	<b>-N</b>	<b>-V</b>	<b>-P</b>	<b>-SF40</b>	<b>-FL</b>	<b>-O2</b>

CSD-6464 2021\_ENG Rev. 0

## Wafer check valve, Article CSD-6464

Diameter DN 125 (5“) up to DN 350 (14“)

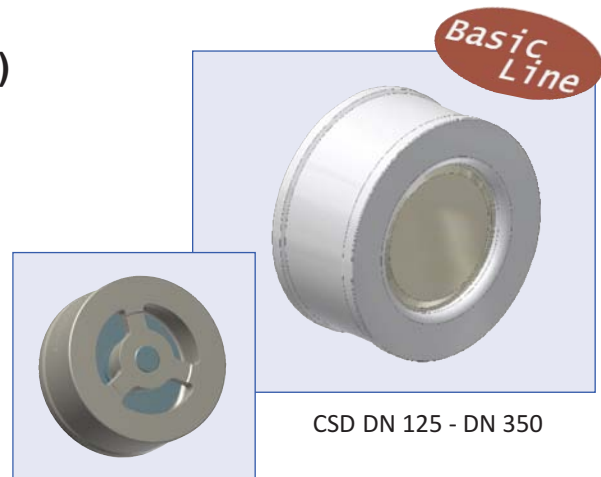
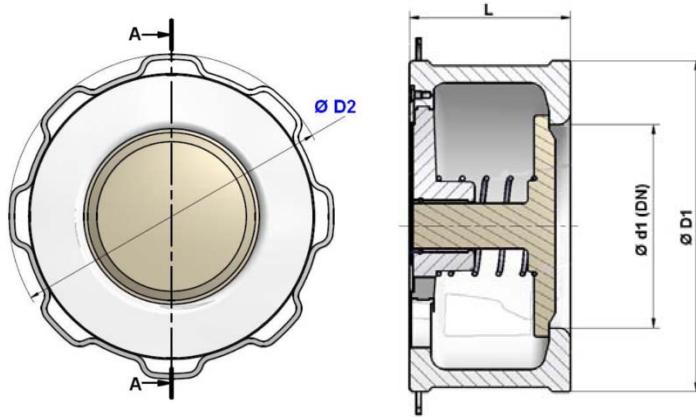

Diameter	article-no.	L (mm)	Ø d1 (mm)	Ø D1 (mm)		Ø D1 / Ø D2 (mm)		opening pressure (mbar) at flow direction			KV-value (m³/h)	weight (kg)
				PN 10	PN 16	PN 25	PN 40	→	↑	↓		
DN 125	286.1463.6.28	90	125	192	192	192	192	22	37	7	180	10
DN 150	286.1463.6.29	106	150	218	218	226	226	25	40	10	270	14
DN 200	286.1463.6.31	140	200	273	273	283	290	28	46	10	450	24
DN 250	286.1463.6.33	200	250	328	328	338	352	42	69	15	700	50
DN 300	286.1463.6.34	250	300	378	378	400	417	44	73	15	950	77
DN 350	286.1463.6.35	280	350	438	444	457	474	44	73	15	1200	108

For the blue marked pressure classes a centering ring must be used. D2 stands for the outside diameter of the centering ring.

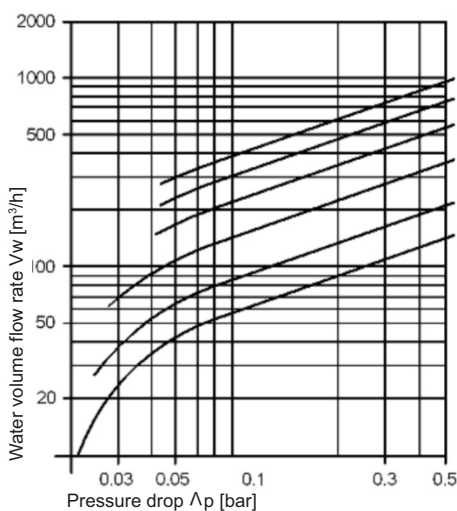

### Pressure drop diagram

Pressure drop diagram for water at 20 ° C with an open valve and horizontal flow. To determine the pressure loss for other media is the equivalent water volume flow to calculate.

$$\dot{V}_w = \dot{v} \sqrt{\frac{\rho}{1000}}$$

$\dot{V}_w$  = equivalent water volume flow in m³/h

$\rho$  = density of the medium in kg/m³ (operating condition)

$\dot{V}$  = Volume flow of the medium in m³/h (operating condition)