

## Flange gate valve, article 512-RG

diameter DN 15 up to DN 100

Flange gate valve made of red brass with non-rising stem made of brass and adjustable gland packing. Wedge metal sealing. Closed design, tightness class B according to EN 12266-1. Flanges are measured and drilled according to EN 1092-3, form A.

**Pressure range up to PN 16.**

For general industrial applications, especially for cold and hot water supply. Operation with hand wheel.

**Design compliant to pressure equipment directive (DGRL97/23/EG), new 2014/68/eu.**



	ambient	-15° C ... + 80° C
	medium	-20° C ... +170° C

### Article 512-RG

Pos.	description	material
1	body	red brass RG 5
2	wedge	brass MS 58
3	stem	brass MS 58
4	top	brass MS 58
5	fibre washer	
6	gland packing	
7	hand wheel	steel plate, red

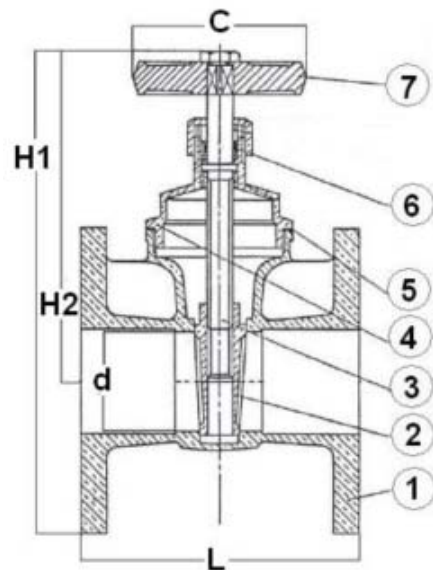

diameter	order number	L (mm)	H1 (mm)	H2 (mm)	d (mm)	C (mm)	screws	pressure rating (PN)	weight (kg)
	512-RG <b>red brass RG5</b>								
DN 15	66.3005.1.11	80	132	85	20	50	4 x M12	16	1,33
DN 20	66.3005.1.13	80	137	87	20	54	4 x M12	16	1,56
DN 25	66.3005.1.15	85	151	95	25	59	4 x M12	16	1,96
DN 32	66.3005.1.18	100	183	117	32	70	4 x M16	16	3,04
DN 40	66.3005.1.19	110	200	125	40	79	4 x M16	16	3,27
DN 50	66.3005.1.21	125	227	149	50	80	4 x M16	16	5,38
DN 65	66.3005.1.24	140	271	181	70	120	4 x M16	16	7,61
DN 80	66.3005.1.25	150	310	210	80	120	4 x M16 / 8 x M16	10 / 16	11,79 / 9,21
DN 100	66.3005.1.27	170	355	240	100	140	8 x M16	16	14,50

512-RG\_ENG\_2017\_Rev.0