

Pneumatic double piston rotary actuator for butterfly valves and ball valves with 90° movement

Article DR 1200 = double acting
Article SC 1200 = single acting



The latest generation of pneumatic actuators offers a high quality standard and innovative solutions for example such as the light outer rotation angle setting of 75° up to 95°, single-acting actuators with safety springs and same dimensions.

High-tech elastomer O-rings allow a standard temperature-range from -40° C to +80° C. The most varied outer surface protection systems enable them to be used even under extreme conditions.

Valve connection ISO 5211 F14 (F12 optional)
octagonal shaft connection according to DIN 3337 36,0 mm

Plug inserts allow the reduction to 27.0 mm or 22,0 mm

Standard with puck on the top at the housing for the visionary position indicator.

	Pressure Equipment Directive 2014/68 / EU (PED)
	Environment -40°C ... +80°C
	SIL 3 according to IEC 61508
	ATEX 94/9/EC II2 GD EEx D IIB T6

Technical data standard design

construction type Pneumatic double piston rotary actuator, same dimension double- or single-acting. safety springs in the end cap provide the safety position optionally OPEN or CLOSE

Mounting position random

Interface actuator / signaling device according to VDI / VDE 3845 (NAMUR)

Norms **Interface actuator / solenoid valve** according to NAMUR or VDI/VDE 3845

Interface actuator / valve Four- or octagonal plug insert with ISO 5211 mounting hole pattern in the actuator body

ambient temperature -40° C up to + 80° C NBR-seal kit (standard)
 -15° C up to +150° C Viton-seal kit
 -55° C up to + 80° C Super-low temperature

torque 3 Nm up to 13.000 Nm

control pressure 2,0 bar up to 8,0 bar (Ü)

control medium filtered air, with respect to residual oil content, dust and water, minimum according to DIN 8573-1

air pressure quality class 4, particle size < 30 µm
 Tp < 20° C, Tp minimum +10° C

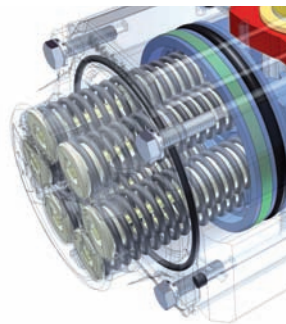

spring package

- service-friendly safety springs
- number of springs variable according to control pressure
- protected against corrosion

spring arrangement:

S 4 = 4 springs S 5 = 5 springs S 6 = 6 springs
 S 7 = 7 springs S 8 = 8 springs S 9 = 9 springs
 S10 = 10 springs S11 = 11 springs S12 = 12 springs

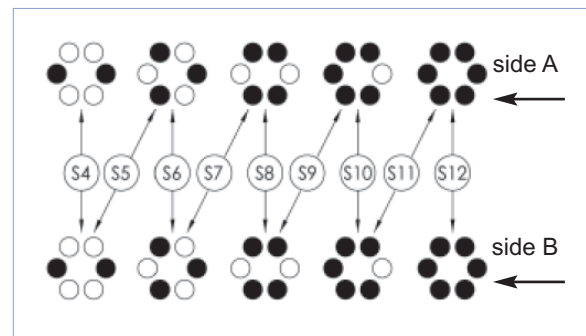

Pneumatic double piston rotary actuator for butterfly valves and ball valves with 90° movement

Article DR 1200 = double acting

Article SC 1200 = single acting



Possible mounting options for pneumatic actuators



Depending on the installation location and the atmospheric load, the following may be selected coating systems

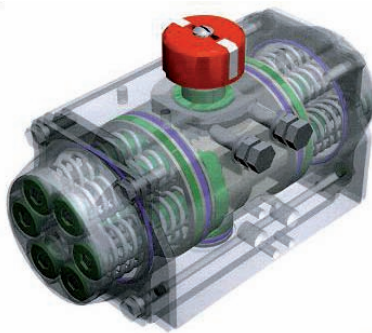

description	design	parts and coating				installation site
		housing	cap	stem	piston	
	Code "A" standard	ALODUR 30 - 35 µm silver grey	anodized + polyester 80 - 90 µm light gray	chemically nickel plated ENP 25 - 30 µm	anodized 15 - 20 µm black	process industry solvent resistant
	Code "B"	anodized + PTFE coated 50 - 55 µm	anodized + polyester coated 95 - 110 µm	chemically nickel plated ENP 25 - 30 µm	anodized 15 - 20 µm black	general industry light to medium loaded atmosphere
	Code "E"	anodized + PTFE coated 50 - 55 µm	anodized + PTFE coated 50 - 55 µm	stainless steel (1.4401)	anodized 15 - 20 µm black	strong environmental influences, strong acidity and basic atmosphere
	Code "EC"	anodized + + 1 primer + 2 Epoxy coating 85-120 µm	anodized + + 1 primer + 2 Epoxy coating 70 - 105 µm	stainless steel (1.4401)	anodized 15 - 20 µm black	direct lake vicinity On- / Offshore applications

pneum._actuator_DR-SC-1200_ENG_2017_Rev.0

pneumatic actuator, DR/SC 1200

Dimensions in mm

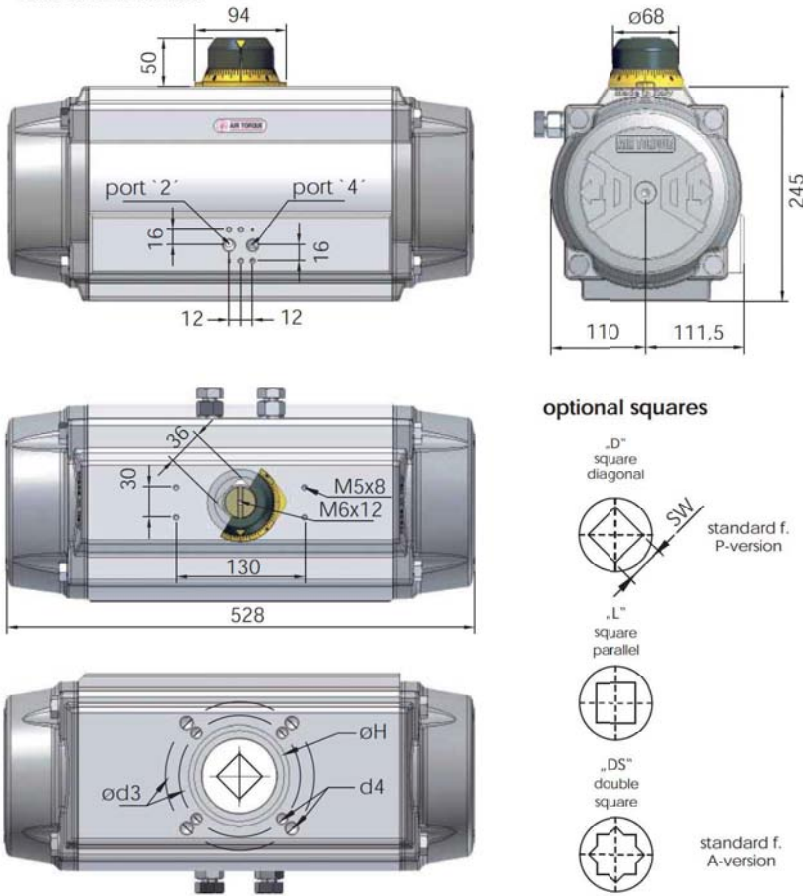

ISO 5211 - available flanges

ISO 5211	Standard		optional	
	F14	F10* + F12*		
Ø d2	100	-	85	
Ø d3	140	102	125	
d4	M16 x 24	M10 x 15	M12 x 18	
Ø H	100	-	85	
SW x l min.	D	-	22 x 40 - 36 x 40	
	DS	36 x 40	27 x 40 - 36 x 40	
h min.	2	2	2	
h1	3	-	1,5	

*before selecting the flange connection please consider the indications of standard n° 5211 on page 0911 of our manual for op. and maintenance

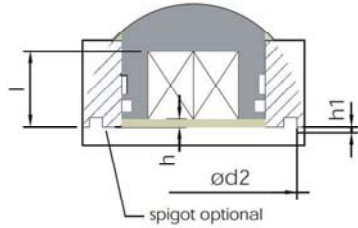

Connection / Attachment

Pressure connection port 2 and 4	G1/4"
Ancillaries attachment	AA 4

Rotation and stroke adjustment

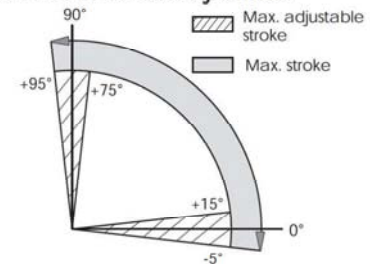

Pressure	Output torque for double acting and spring return in Nm												Spring torque		approx. weight in kg									
	2,5 bar		3 bar		3,5 bar		4 bar		4,2 bar		4,5 bar		5 bar			5,5 bar		6 bar		7 bar		8 bar		
	0°	90°	0°	90°	0°	90°	0°	90°	0°	90°	0°	90°	0°	90°		0°	90°	0°	90°	0°	90°	0°	90°	
DR	532	638	745	851	893	957	1064	1170	1276	1489	1702	-	-	-	-	-	-	-	-	-	-	-	-	34,3

SC 2/3	319	217	426	323	532	430	638	536	681	578	745	642	851	749										315	213	38,2	
SC 3	277	154	383	260	489	367	596	473	638	515	702	579	808	686	915	792									378	255	39
SC 3/4			341	197	447	304	553	410	596	453	660	516	766	623	872	729	979	835							441	298	39,7
SC 4					404	241	511	347	553	390	617	453	723	560	830	666	936	772	1149	985					504	340	40,5
SC 4/5							468	284	511	327	575	390	681	497	787	603	894	709	1106	922	1319	1135			567	383	41,3
SC 5											532	327	638	434	745	540	851	646	1064	859	1277	1072			630	425	42
SC 5/6													596	371	702	477	809	583	1021	796	1234	1009			693	468	42,8
SC 6															660	414	766	520	979	733	1192	946			756	510	43,6

Pressure max.	Rotation (STD) (C)	Screw stroke adjustment	Chamber Ø (mm)	Air volume (l)		Moving time (sec.) (A)	
				OPEN	CLOSE	OPEN	CLOSE
8 bar	0° - 90°	for 1° 1/4 rotation	200	5,94	9,46	D 2,7 S 3,5	D 3,2 S 4,0

Operating temperature (°C) (B)		
ST (Standard)	HT (High temperature)	LLT (Extreme low temperature)
- 40 to + 80	- 15 to + 150	- 55 to + 80

(A) the above indicated moving time of the actuator is obtained under the following test conditions: (1) room temperature, (2) actuator stroke 90°, (3) solenoid valve with Ø 11 mm and flow capacity Qn 6000 L/min. (4) inside pipe Ø 11 mm, (5) medium clean air (6) air supply pressure 5,5 bar (79,75 Psi), (7) actuator without external resistance load. **Caution:** It has to be expected, e.g. for field applications, when one or more of the above parameters are different, the moving time will be different.

Operating Medium:

The operating medium must be free of dust and oil. The maximum particle size must not exceed 30µ (ISO 8573 Part1, Class5). In order to prevent water condensation and/or solidification (ice when actuator works below 0°C), the operating medium must have a dew point equal to -20°C or at least 10°C below the ambient temperature (ISO 8573 Part1, Class 3).

(B) Every temperature range option requires proper components and lubricant. Please contact BSA Armaturen.

pneumatic actuator, DR/SC 1200

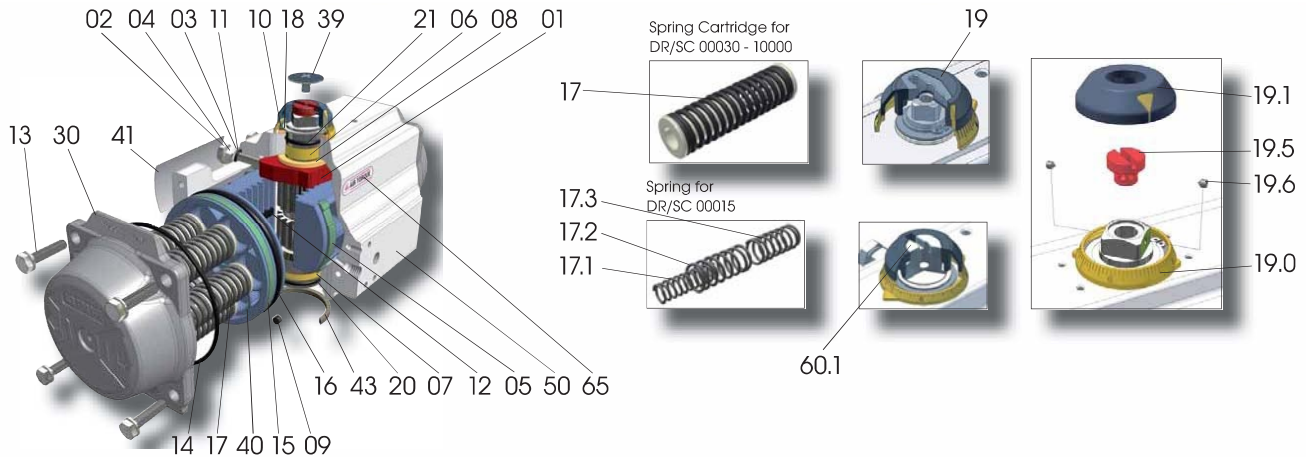

Pos.	Quantity / Note	Description	Material	
01	1	Octi-Cam (Stop arrangement)	Stainless Steel (for DR/SC00015U - DR/SC00150U) Carbon Steel / Nodular Cast Iron, zinc coated	
02	2	Stop Cap Screw	Stainless Steel	
03	2	Washer	Stainless Steel	
04	2	Nut (Stop screw)	Stainless Steel	
05	2	Bearing (Piston top)	hochwertiger Kunststoff	
	4			for DR/SC 10000U
06	1	Bearing (Pinion top)	high-grade plastic	
07	1	Bearing (Pinion bottom)	high-grade plastic	
08	2	Thrust bearing	high-grade plastic	
09	2	Plug	Silicone	
09.1	2	for DR/SC 05000U-10000U	O-Ring plug	M-NBR
10	1	Thrust Washer	Stainless Steel	
11	2	O-Ring (Stop screw)	M-NBR	
12	2	Piston Guide	high-grade plastic	
13	8	for DR/SC 00015U-02000U	Cap Screw	Stainless Steel
	12	for DR/SC 03000U-04000U		
	16	for DR/SC 05000U-10000U		
13.1	16	for DR/SC 10000U	Washer (Cap screw end cap)	Stainless Steel
14	2	O-Ring (End cap)	M-NBR	
15	2	Bearing (Piston head)	high-grade plastic	
16	2	O-Ring (Piston)	M-NBR	
17	max.12	for DR/SC 00030U-10000U	Spring Cartridge	SiCr Spring Steel
17.1	max. 2	for DR/SC 00015U	Spring	
17.2			Spring	
17.3			Spring	
18	1	Spring Clip	SiCr Spring Steel, ENP	
19	1	for DR/SC 00015U-00030U	Position Indicator	high-grade plastic / Stainless Steel
19.0	1	Graduated Ring	high-grade plastic	
19.1	1	for DR/SC 00015U-00030U	Position Indicator	high-grade plastic
19.5	1	for DR/SC 00015U-00030U	Top Adaptor	Extruded Aluminium alloy, anodized
19.6	2	for DR/SC 00015U-00030U	Hex. Socket Screw (Top adaptor)	Stainless Steel
20	1	O-Ring (Pinion bottom)	M-NBR	
21	1	O-Ring (Pinion top)	M-NBR	
30	2	End Cap	Pressure Die Cast Aluminium alloy, coated Cast Aluminium alloy, coated (DR/SC10000)	
39	1	Cap Screw (Indicator)	high-grade plastic	
40	2	Piston	Pressure Die Cast Aluminium alloy, coated Cast Aluminium alloy, coated (DR/SC10000)	
41	1	Label	Polyester Aluminium	
43	1	Spigot (on request*)	Extruded Aluminium alloy, anodized	
50	1	Body	Extruded Aluminium alloy, coated Cast Aluminium alloy, coated (DR/SC 05000+10000)	
60	1	Drive Shaft	Extruded Aluminium alloy, anodized (DR/SC10000) Carbon Steel, ENP	
60.1	1	not for all types	Integral Drive Shaft	Stainless Steel, ENP
65	1	Plastic Insert	high-grade plastic	

○ enclosed in spare part kit □ enclosed in O-Ring kit *on request

pneum_actuator_DR-SC-1200_ENG_2017_Rev0